



# Artikelgruppe 1150-1160 T

## Kraftspanner verschiebbar

Combined Sliding Clamp

Referenz-Nr. Order No.	a	m	h		s	s1	e1	d	sw	L	e	b	c	Spannkraft Clamping Force Kgf	 (g)	
			min	max												
1150-118 T	18	M16	0	65	18-96	35	125	M20	12	140	43	55	19.5	2500	4410	
1150-120 T	20	M16	0	65	18-96	35	125	M20	12	140	43	55	19.5	2500	4460	
1150-122 T	22	M16	0	65	18-96	35	125	M20	12	140	43	55	19.5	2500	4515	
1150-124 T	24	M16	0	65	18-96	35	125	M20	12	140	43	55	19.5	2500	4620	
1150-128 T	28	M16	0	65	18-96	35	125	M20	12	140	43	55	19.5	2500	4725	
																
1160-222 T	22	M20	20	80	17-92	41.5	175	M24	12	24	178	55	74	24	5500	9030
1160-224 T	24	M20	20	80	17-92	41.5	175	M24	12	24	178	55	74	24	5500	9120
1160-228 T	28	M24	20	80	17-92	41.5	175	M24	12	24	178	55	74	24	5500	9180
1160-236 T	36	M24	20	80	17-92	41.5	175	M24	12	24	178	55	74	24	5500	9600

### 1150-1160

• **1150** (a) 18-28 in T-Nut wird Imbusschraube M16 DIN 508 mit T-Nutmutter verwendet. Spannhöhe 0-65 mm, Spannweite 78 mm, Spannkraft 2500 kgf.

• **1160** (a) 22-36 in T-Nut wird Imbusschraube M20-M24 DIN 508 mit T-Nutmutter verwendet. Spannhöhe 20-80 mm, Spannweite 73 mm, Spannkraft 5500 kgf.

### 1150-1160

• **Nr. 1150** (a) 18-28 is used in T-Slot and M16 imbus bolt is used with DIN 508 T-Nut. Height clamping gap of the piece is 0-65mm, back-and-forth movement distance is 78mm. Clamping force is 2500 kgf.

• **Nr. 1160** (a) 22-36 is used in T-Slot and M20-M24 imbus bolt is used with DIN 508 T-Nut. Height clamping gap of the piece is 20-80mm, back-and-forth movement distance is 73mm. Clamping force is 5500 kgf.

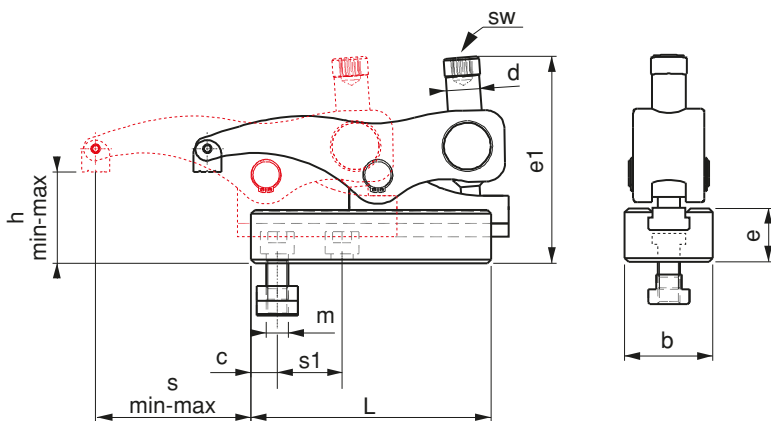

#### ANWENDUNG;

- 1- Zwischenelement an Werkstück befestigen
- 2- Grundkörper auf Zwischenelement verschieben
- 3- Werkstück mit Imbusschraube befestigen
- 4- Werkstück ist zum Bearbeiten bereit

#### APPLICATION;

- 1- Slide cradle is brought to suitable form with the work piece and then it is fixed
- 2- Upper body is driven to the slide and it is brought to desired position
- 3- Work piece is fixed with the imbus bolt of the clamp
- 4- Then the work piece becomes ready to be machined.

#### Verwendung

Injektionsmaschinen, Pressen, Fräsmaschinen, Bohrzentren, verschiedene Industriemaschinen

#### Area of Use

Injection Machines, Presses, Milling Machines, Drilling Machines and various Industrial Machines

